

# HEAT EXCHANGER UNIT SLUDGE/SLUDGE

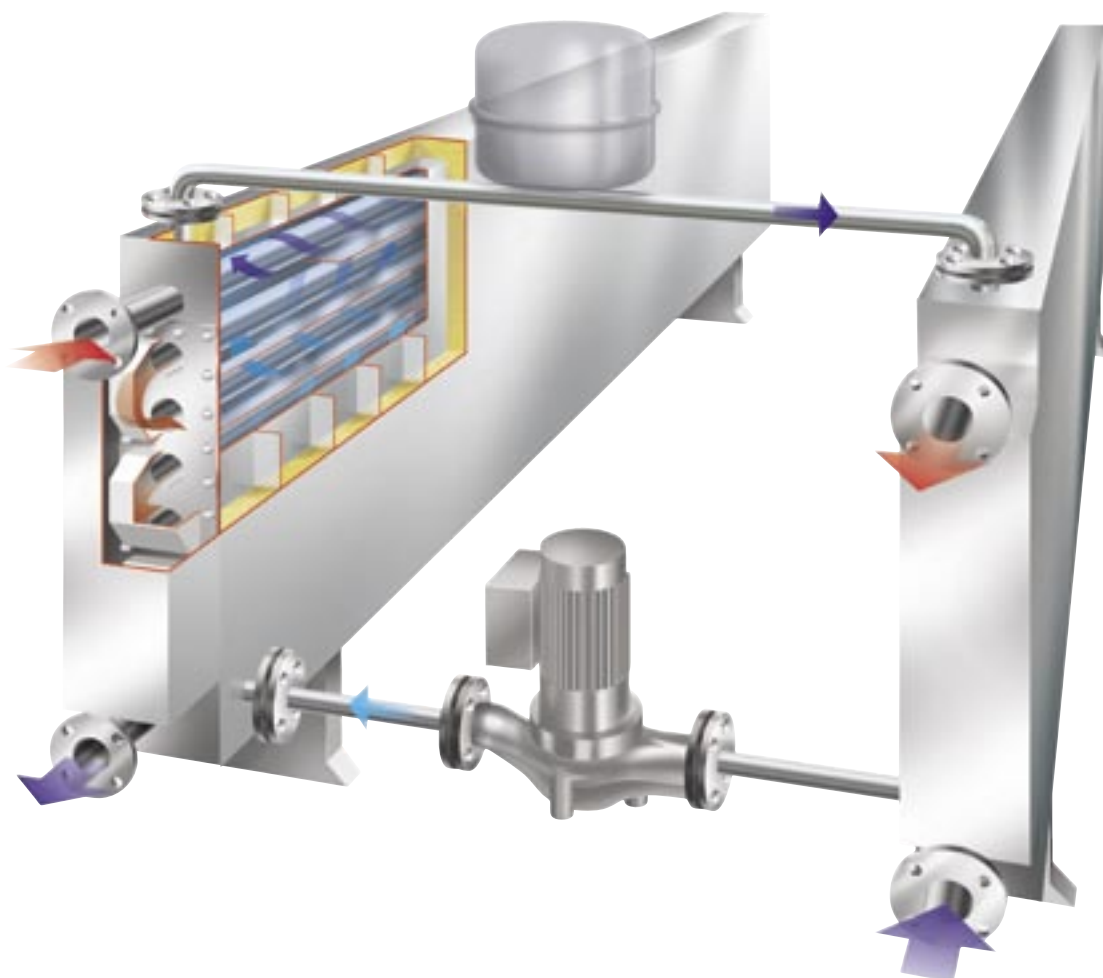

**Heat exchanger units sludge/sludge from Läckeby Products are a further development of the heat exchanger sludge/water. The unit, which combines innovative thinking with 40 years' of experience in this sector, has been developed for the special requirements set for heat recovery from hygenisated or digested sludge. This unique patented design provides a compact unit with minimal maintenance requirements.**

## Function

The heat exchanger unit sludge/sludge consists of two heat exchangers sludge/water connected by a closed water circuit. This creates a compact unit that is simple to install and minimises installation volume. The closed water circuit between the heat exchangers eliminates the risk of digested or hygenisated sludge being contaminated by raw sludge. Circular sludge channels deliver a large throughput area, which means low pressure loss and a minimised risk of clogging. Inspection, disassembly and maintenance are made easier because the patented turning chambers are mounted on a common flange. The turning chambers also provide higher temperature transfer by equalising the sludge's temperature profile. Based on a modular principle and patented turning chambers, the compact design delivers low running costs. This makes the heat exchanger unit from Läckeby Products a good investment.

## Technical features

- Unique design specifically for sludge
- Patented turning chamber
- Compact unit that is easy to install
- Simple inspection and maintenance
- High heat transfer
- Large throughput area
- Closed water circuit between two separate heat exchangers

## Process benefits

- Enhances efficiency of digestion and hygenisation
- Equalises the sludge's temperature profile
- Makes maintenance easier and eliminates problems with multiple flanges and loose connections
- Minimises installation volume
- Reduces pressure losses
- Minimises risk of clogging
- Eliminates risk of sludge contamination

## Design

The heat exchanger unit sludge/sludge is a compact design with circular sludge channels surrounded by rectangular water circuits. Based on a modular principle and patented turning chamber, the heat exchanger unit can be adapted to the unique conditions of each plant.

As standard, the heat exchanger unit sludge/sludge is manufactured in stainless steel (1.4436) with cover plates and supports in stainless steel (1.4301). The water circuit with pipes, pump and pressure vessel is not normally included in deliveries from Läckeby Products.

## Temperature and flow examples

	Example 1	Example 2	Example 3
T1	10 °C	12 °C	10 °C
T2	42 °C	43 °C	41 °C
T3	70 °C	70 °C	70 °C
T4	38 °C	38 °C	38 °C
Q1	5 m <sup>3</sup> /h	5 m <sup>3</sup> /h	7 m <sup>3</sup> /h
Q2	5 m <sup>3</sup> /h	5 m <sup>3</sup> /h	7 m <sup>3</sup> /h
Q3	30 m <sup>3</sup> /h	30 m <sup>3</sup> /h	30 m <sup>3</sup> /h
Q4	12 m <sup>3</sup> /h	7.5 m <sup>3</sup> /h	15 m <sup>3</sup> /h

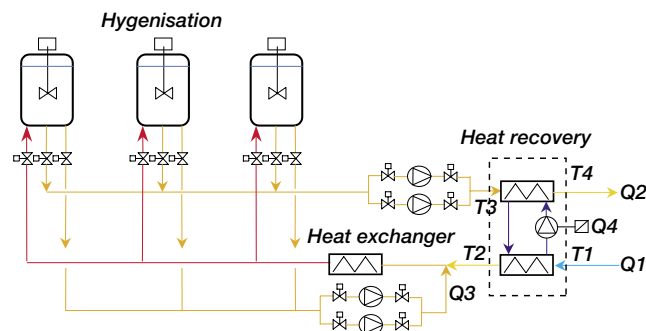

Due to the variable water flow (Q4), the temperature of the digestion chamber (T4) after the hygienisation process can be kept constant, regardless of the inlet temperature (T1) and sludge flow rates (Q1) and (Q2).



Two heat exchanger units sludge/sludge installed at Vimmerby wastewater treatment works.

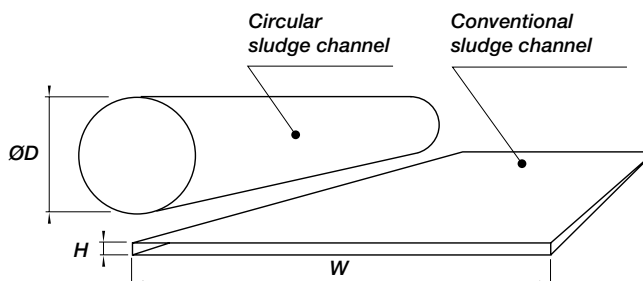

## References

Since the 1990s, Läckeby Products has supplied over 100 heat exchanger sludge/water and heat exchanger units sludge/sludge to municipal and industrial plants worldwide.

Läckeby Products develops, designs and manufactures heat exchangers. Coordinated expertise and production ensures high quality service and delivery. Läckeby products can also participate in the planning stage and take on responsibility for everything from dimensioning to installation. Through our involvement at the planning stage, we can offer a total process guarantee.

### LÄCKEBY PRODUCTS

**Läckeby** Mosekrogsvägen 2, SE 380 31 Läckeby, Sweden  
Phone +46 480-381 00  
Fax +46 480-606 63

**Kungälv** Bultgatan 28, SE 442 40 Kungälv, Sweden  
Phone +46 303-24 64 80  
Fax +46 303-928 90

[www.lackebyproducts.com](http://www.lackebyproducts.com)

# HEAT EXCHANGER SLUDGE/WATER

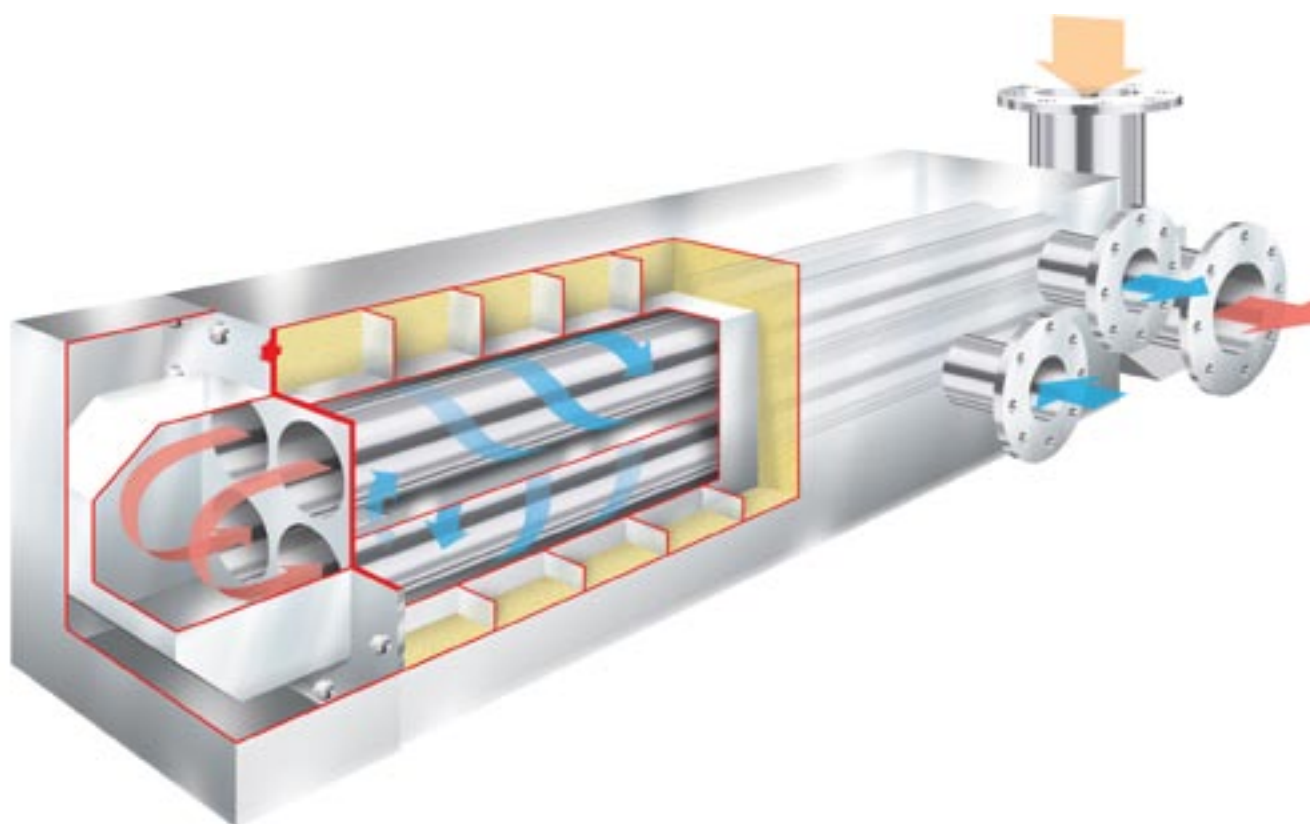

**Heat exchanger sludge/water from Läckeby Products combine innovative thinking and 40 years' experience in this sector. This unit has been developed to meet special requirements for the heating or cooling of sludge. The unique patented design provides a compact heat exchanger with minimal maintenance needs.**

## Function

Läckeby Products produces heat exchangers sludge/water based on a modular principle with circular sludge channels, which means the design can be adapted to each plant's unique conditions. The channels provide a large throughput area that keeps pressure loss low and minimises the risk of clogging. Each level of sludge channels is surrounded by a rectangular water circuit, in which water for heating/cooling flows in the opposite direction to the sludge.

The unique patented open turning chamber contributes to a compact design that is simple to install. Inspection, disassembly and maintenance are made easy because the turning chambers are mounted on a common flange. The turning chambers provide even higher heat transfer by equalising the sludge's temperature profile. Based on a modular principle and patented turning chambers, the compact design delivers low running costs. This makes heat exchangers from Läckeby Products a good investment.

## Technical features

- Unique design specifically for sludge
- Patented turning chamber
- Compact unit that is easy to install
- Simple inspection and maintenance
- High heat transfer
- Large throughput area

## Process benefits

- Enhances efficiency of digestion and hygienisation
- Makes maintenance easy
- Eliminates problems with multiple flanges and loose connections
- Equalises temperature profile of sludge
- Reduces pressure losses
- Minimises risk of clogging

## Design

The heat exchanger sludge/water is a compact design with circular sludge channels based on a modular principle and patented turning chamber. As standard, the unit is made in stainless steel (1.4436) with cover plates and supports in stainless steel (1.4301).

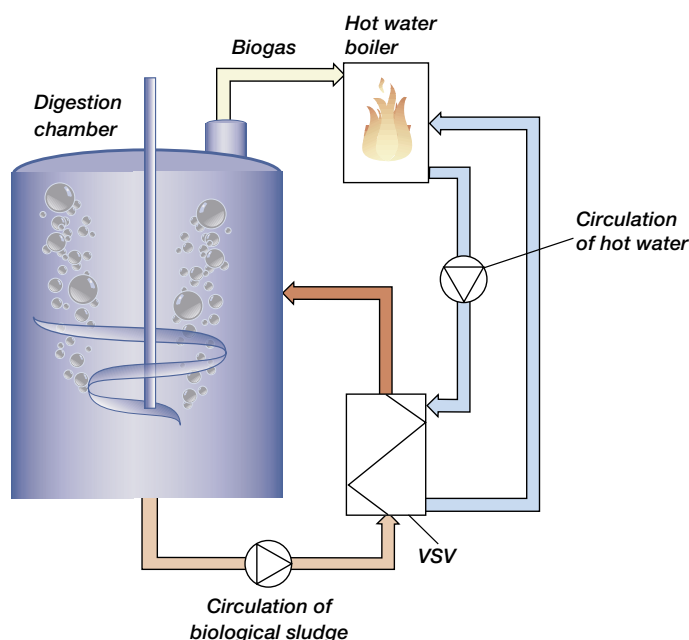

Heat exchanger sludge/water and heat exchanger unit sludge/sludge from Läckeby Products installed in Älmhult.

	Example VSV 80	Example VSV 40
Sludge flow	73 m <sup>3</sup> /h	6 m <sup>3</sup> /h
Inlet sludge temperature	55.0 °C	5.0 °C
Outlet sludge temperature	55.6 °C	31.0 °C
Hot water flow	12 m <sup>3</sup> /h	8 m <sup>3</sup> /h
Inlet water temperature	68.0 °C	75.0 °C
Outlet water temperature	64.1 °C	55.0 °C
Heat transfer	55 kW	183 kW

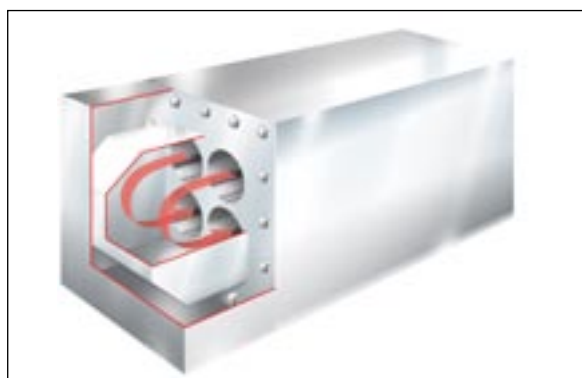

The turning chamber, patented by Läckeby Products, facilitates a compact design and makes disassembly and maintenance routines easy.

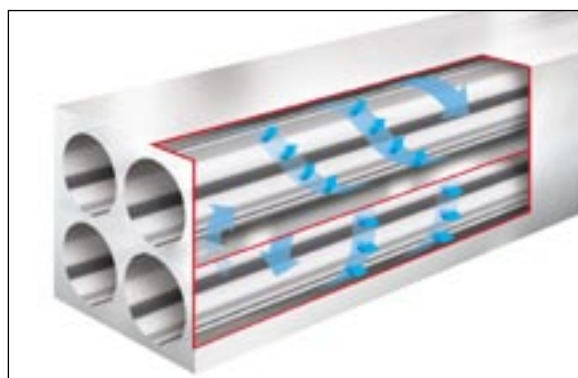

Hot/cold water circulates around the sludge pipe in a rectangular pressure vessel.

## References

Since the 1990s, Läckeby Products has supplied over 100 heat exchangers sludge/water and heat exchanger units sludge/sludge to municipal and industrial plants worldwide.

Läckeby Products develops, designs and manufactures heat exchangers. Coordinated expertise and production ensures high quality service and delivery. Läckeby Products can also participate in the planning stage and take on responsibility for everything from dimensioning to installation. Through our involvement at the planning stage, we can offer a total process guarantee.

### LÄCKEBY PRODUCTS

**Läckeby** Mosekrogsvägen 2, SE 380 31 Läckeby, Sweden  
Phone +46 480-381 00  
Fax +46 480-606 63

**Kungälv** Bultgatan 28, SE 442 40 Kungälv, Sweden  
Phone +46 303-24 64 80  
Fax +46 303-928 90

[www.lackebyproducts.com](http://www.lackebyproducts.com)